

Dumper

DM9





- non disponible
● de série
○ en option

CARACTERISTIQUES	DM9		
Performances			
Masse totale à vide (kg)	8100		
Capacité de charge maximale (kg)	9000		
Volume à pleine charge iso6483 (m3)	4.9		
Volume à ras (m3)	3.7		
Volume d'eau (m3)	2.9		
Angle de basculement max	75°		
Rotation de la plaque tournante	± 90°		
Hauteur de déchargement (mm)	1200		
PowerTrain			
Moteur	DEUTZ TCD3.6		
Puissance moteur (kW/HP)	74.4/100		
Technologie anti-pollution	STAGE V		
Réservoir de carburant (l)	200		
Réservoir AdBlue (l)	18		
Essieux	Sur portique		
Transmission hydrostatique	EPD		
Pente maximale surmontable à pleine charge (%)	40		
Pente maximale surmontable à vide (%)	50		
Pente transversale maximale (%)	15		
Vitesse maximale (km/h)	40		
Nombre de vitesses	2		
Configuration			
Cabine FOPS/ROPS	●		
Double position de conduite	●		
Freins	4 à disques secs		
Frein de stationnement	●		
Quatre roues motrices	●		
Quatre roues directrices	●		
Trois types de braquage	●		
Pneus standard	18-19,5"		
Crochets de remorquage avant et arrière	●		
Coupe-batterie automatique	●		
Batterie	100Ah - 12V		
Compartiments à outils	2		
Caméra arrière	●		
Climatisation	○		
Phares de travail	○		

Dimensions



	DM9	
A (mm)	4920	
B (mm)	2100	
C (mm)	2750	
D (mm)	820	
E (mm)	880	
F (mm)	500	
F1 (mm)	495	
G (mm)	1885	
H (mm)	2335	
I (mm)	1200	
L (mm)	2200	
M (mm)	2630	
N (mm)	4130	
O (mm)	3020	
P (mm)	4010	
Q (mm)	250	
R (mm)	4190	
S (mm)	4730	

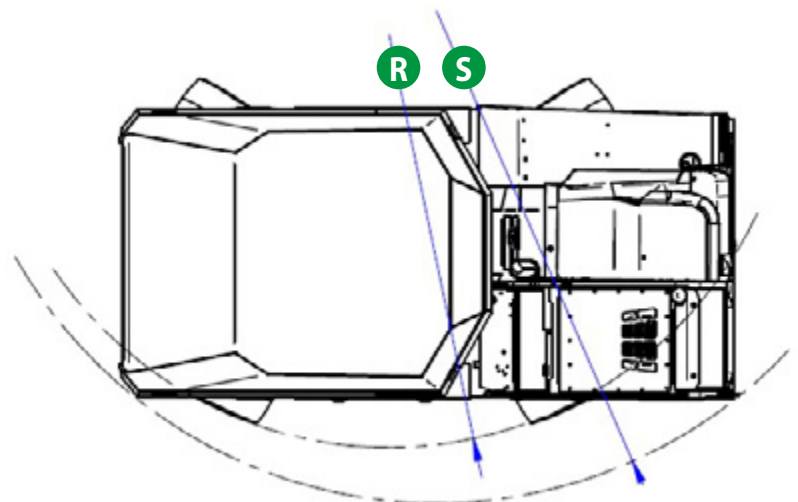
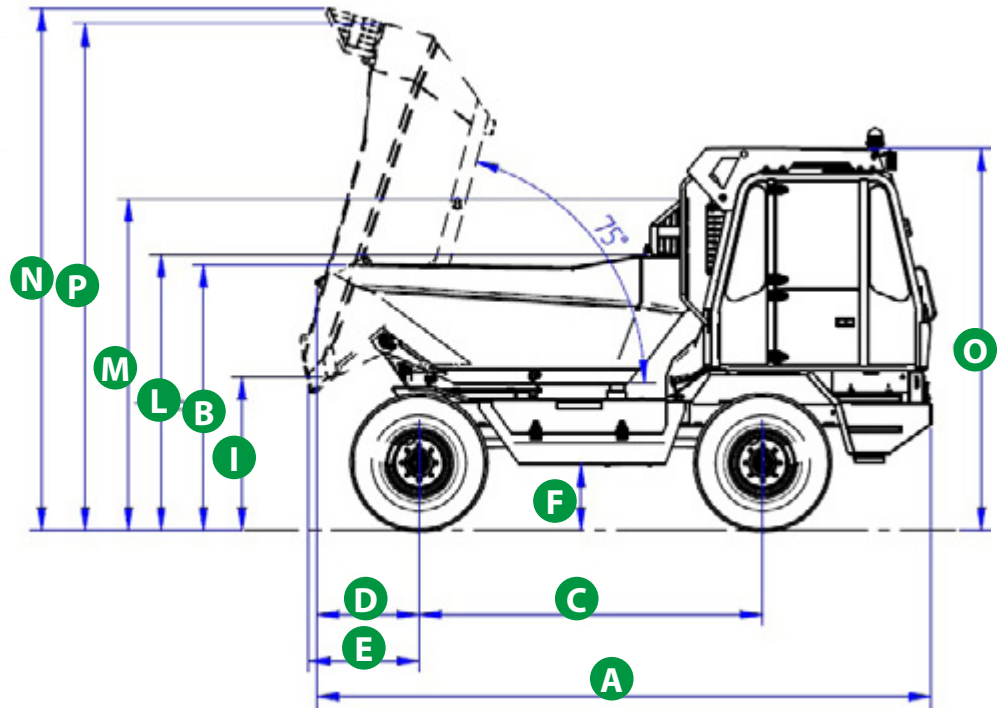
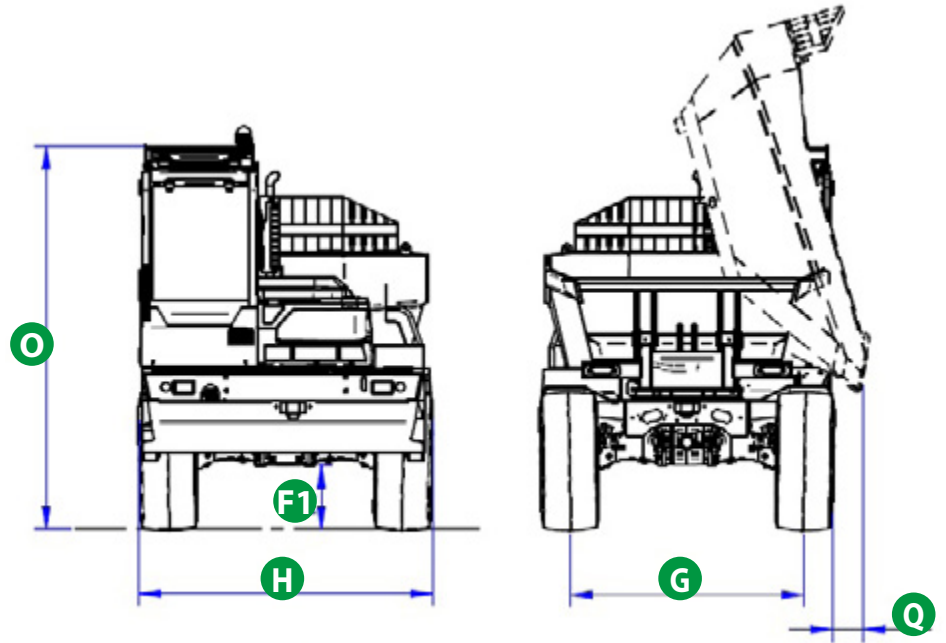

Votre concessionnaire Merlo

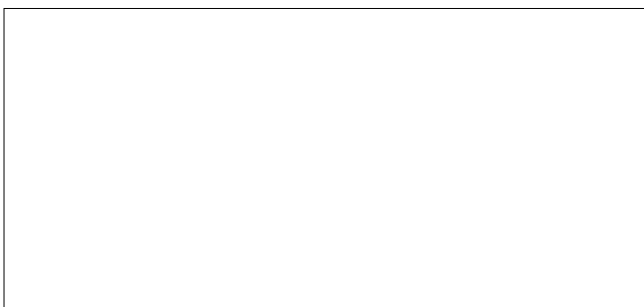

MERLO S.P.A.

Via Nazionale, 9

12010 S. Defendente di Cervasca, (Cuneo) Italia

Tel. +39 0171 614111

Fax +39 0171 684101

info@merlo.com

www.merlo.com

